



Fully intercost

# Interchangeable with SN/SD plummer blocks

The New compact Split Plummer Block Bearing from SRB is the first split cylindrical roller bearing assembly to be interchangeable with standard SN and SD series plummer blocks, bringing the benefits of a split design to a much wider audience.

Split roller bearings offer dramatically reduced downtime in maintenance and replacement situations, but could not previously be used in many bearing applications because of their dimensional incompatibility with standard plummer block sizes.

Key benefits of the Split Plummer Block are:

- SRB SN & SD Series supports dimensionally interchangeable with the SN5.. and SD31.. range of plummer blocks
- Significant reductions in the time required to change trapped bearings
- Savings in downtime, improved machine availability
- Simplified mounting procedures, no feeler gauges
- Improved sealing efficiency, seals remain concentric to the shaft, unlike spherical roller bearings
- Efficient use of Maintenance Engineering resources
- Improved reliability, able to accommodate thermal expansion of the shaft within the bearing envelope



Cast iron plummer blocks accommodating adapter sleeve mounted spherical roller bearings are amongst the most common types in use, supporting rotating shafts in everything from conveyors and fans to line shafts. Yet their replacement is often time consuming and difficult due to the removal of adjacent equipment. Replacing a typical bearing mounted in a cast iron plummer block can take anything from 6 hours to several days, in contrast, it can take as little as 1-2 hours to replace an SRB bearing unit.

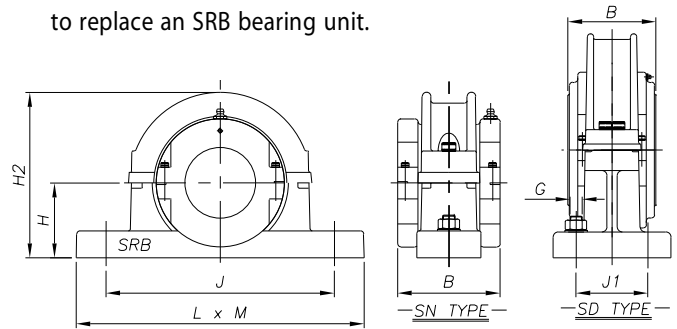

SRB REF	SN / SD REF	H	H2	B	J x J1	L x M	G	SHAFT SIZE
SN01	SN 508	60	135	84	170	205 x 60	12	ø5
	SN 509							ø10
SN02	SN 511	70	155	96	210	255 x 70	16	ø5
	SN 512							ø5
SN 03	SN 513	80	180	102	234	275 x 70	16	ø6
SN 03A	SN 515							ø5
SN 04	SN 516	95	208	112	260	315 x 90	20	ø7
	SN 517							ø5
SN 05	SN 518	100	230	134	290	345 x 100	20	ø8
SN 05A	SN 519	112	242					ø5
SN 05B	SN 520				320	380 x 110	24	ø9
SN 06	SN 522	125	265	132	350	410 x 120	24	ø100
SN 07	SN 524	140	300	140	350	410 x 120	24	ø110
SN 07A	SN 526	150	310		380	445 x 130		ø15
SN 08	SN 528	150	354	154	420	500 x 150	30	ø25
SN 09	SN 530	160	369	166	450	530 x 160	30	ø35
SN 09A	SN 532	170	379	166	470	550 x 160	30	ø40
SD 10	SD 3134	170	379	172	430 x 100	510 x 180	24	ø50
SD 11	SD 3136	180	396	172	450 x 110	530 x 190	24	ø60
SD 12	SD 3138	190	417	172	480 x 120	560 x 210	24	ø70
SD 12A	SD 3140	210	437		510 x 130	610 x 230	30	ø80
SN 13	SD 3144	220	457	172	540 x 140	640 x 240	30	ø90
SD 14	SD 3148	240	510	176	600 x 150	700 x 260	30	ø220
SD 15	SD 3152	260	545	188	650 x 160	770 x 280	36	ø40
SD 16	SD 3156	280	589	204	670 x 160	790 x 280	36	ø60
SD 16A	SD 3160	300	609		710 x 190	830 x 310		ø80
SD 17	SD 3164	320	662	216	750 x 200	880 x 330	36	ø90

SRB offer a complete design and manufacturing service for special and bespoke applications. Examples include: Ball Mill Support Bearings, Water Cooled Continuous Casters, Industrial High Pressure Pump Bearings, Wire Strander Bearings, Rotary Biological Contactor Support Bearings, Special Seal Design Options.